

# Interpreter's Control Center, Model IC-1

## Description:

This self-contained audio control center lets interpreters listen to the program directly from the floor or another interpreter while simultaneously interpreting into a microphone. Used as a stand-alone unit, the IC-1 is capable of handling dual language applications. Used in tandem, multiple IC-1s may be combined to economically handle up to four languages.

## Interpreter Control Center, Model IC-1:

<b>Dimensions, Weight:</b>	7" (17.7 cm) W x 5.625" (14.3 cm) D x 3.125" (9.3 cm) H, 1.82 lbs (.83 kg)
<b>Color:</b>	Beige epoxy paint with black legends, blue bottom and side panels
<b>Power:</b>	External power supply, 12 VAC, 50 or 60 Hz, 10 VA, (TFP 008 Power Supply) (A 240 VAC Power Supply is also available, TFP 008 HV)
<b>INPUTS</b>	
<b>Floor In, Relay In:</b>	3-Pin XLR female jack, balanced or unbalanced line-level, max. 3.8 Vrms, Gain 6 dB, 43 k $\Omega$ input impedance
<b>1/4" Microphone Inputs:</b>	Left and right, 1/4" TRS phone jack, balanced or unbalanced mic-level, max. 70 mVrms, gain 46 dB, supplies simplex DC power for electret mics, 1.75 k $\Omega$ input impedance
<b>3.5 mm Microphone Inputs:</b>	Left and right, 3.5 mm TRS phone jack, unbalanced (T,S) for condenser mics, max. 70 mVrms, gain 46 dB, supplies DC power on tip, 1.75 k $\Omega$ input impedance
<b>OUTPUTS</b>	
<b>Key Out, Norm Out:</b>	3-Pin XLR male jack, balanced or unbalanced line-level, 7.7 max. Vrms, 56 $\Omega$ source impedance
<b>Phones:</b>	3.5 mm TRS phone jack, mono or stereo headphone, 8-32 $\Omega$ , 63.7 mW at 8 $\Omega$ load max
<b>CONTROLS</b>	
<b>Volume:</b>	Left and right, rotary, controls headphones volume
<b>Mic Switch:</b>	3-way toggle. Selects left mic, right mic, or both.
<b>Mute Switch:</b>	Push button. Mutes left and right mics when depressed.
<b>Function Switch:</b>	4-way push button. Selects OFF, NORM, RELAY, or KEY modes.
<b>OFF Mode:</b>	Floor input (FLOOR IN) is fed to the interpreter's headphones to allow monitoring of the meeting. Interpreter's microphones are muted.
<b>NORM Mode:</b>	Floor input (FLOOR IN) is fed to the interpreter's headphones. The selected interpreter's microphone is fed to the normal output (NORM OUT).
<b>RELAY Mode:</b>	Interpreter monitors the relay input (RELAY IN) while the selected microphone feeds the normal output (NORM OUT)
<b>KEY Mode:</b>	Used to feed a second language audience. The interpreters monitor the floor input (FLOOR IN) while mics feed the key output (KEY OUT).
<b>Feedthru Jumpers:</b>	Located on bottom of cabinet. Used to select floor signal feedthru options.
<b>J1</b>	Feeds the floor signal to the normal output (NORM OUT)
<b>J2</b>	Feeds the floor signal to the key output (RELAY OUT)
<b>Recommended Microphone</b>	
<b>MIC 079</b>	Dual headphone, condenser mic, 3.5 mm plug (MIC 079), Audio Indicator Light: Yellow LED, flashes when audio signal is present
<b>ON Indicator Light:</b>	Green LED, glows when power is applied to the transmitter. There is no on/off switch. The T17 is designed to be left on continuously.
<b>Warranty:</b>	3 years, parts and labor*

\*90 day warranty on accessories

NOTE: SPECIFICATIONS SUBJECT TO CHANGE WITHOUT NOTICE!

# Interpreter's Control Center, Model IC-1

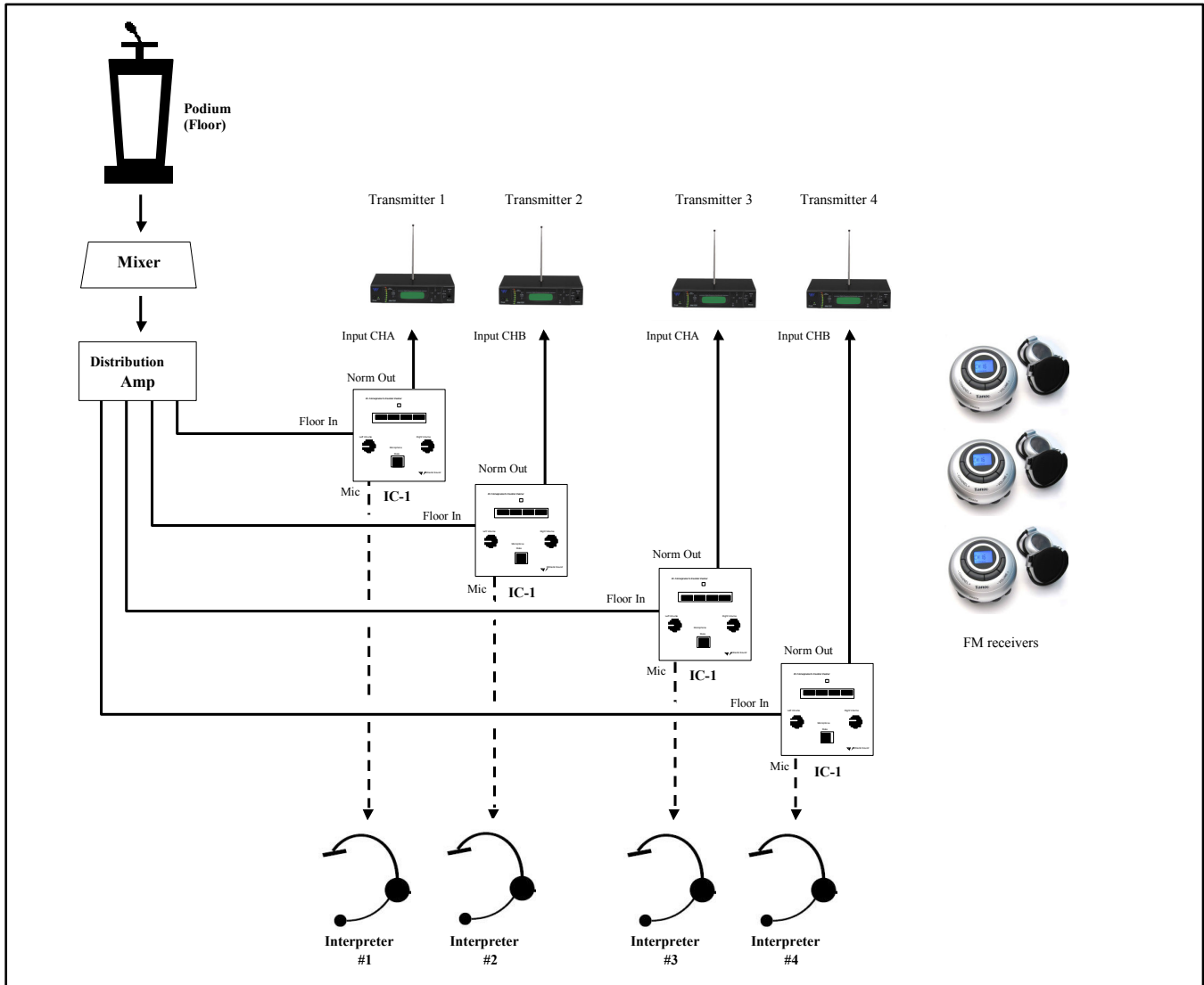
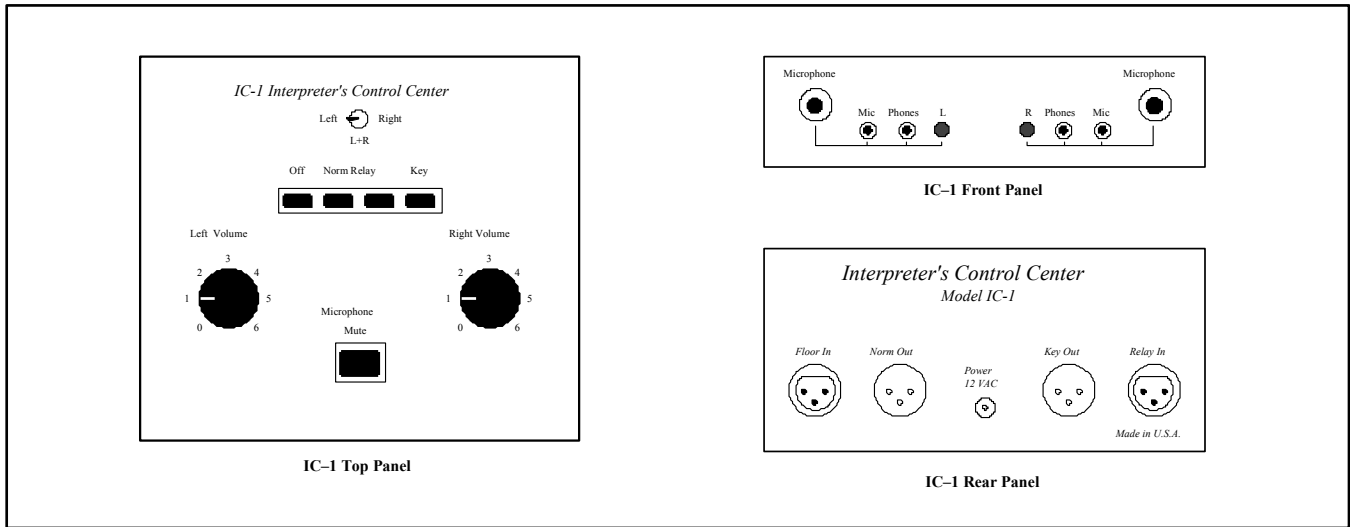

NOTE: SPECIFICATIONS SUBJECT TO CHANGE WITHOUT NOTICE!

# Interpreter's Control Center, Model IC-1

## Bid Specs

The unit shall be 7 inches wide, 5 5 / 8 inches deep and 3 1 / 8 inches tall. The unit shall weigh 1.82 lbs. The module shall be painted beige with black legends indicating controls, inputs and outputs. The bottom and side panels shall be painted blue. The power supply shall be external, 12 VAC, 50 or 60 Hz, 10 VA. An optional 240 VAC Power Supply shall also be available. Inputs shall be configured as follows: The "Floor In" and "Key In" inputs shall be 3-Pin, XLR female jacks, allowing balanced or unbalanced line-level inputs. Maximum input levels shall be 3.8 Vrms. Gain shall be 6 dB with 43 k $\Omega$  input impedance. There shall be two microphone inputs, both 1 / 4" TRS phone jacks, balanced or unbalanced. These inputs shall be mic-level, allowing a maximum 70 mVrms and 46 dB gain. The two microphone inputs shall supply simplex DC power for electret mics with 1.75 k $\Omega$  input impedance. There shall be two independent 3.5 mm TRS microphone inputs (unbalanced [T,S] for condenser mics), allowing a maximum 70 mVrms. Gain shall be 46 dB. The two 3.5 mm inputs shall supply DC power on tip, 1.75 k $\Omega$  input impedance.

NOTE: SPECIFICATIONS SUBJECT TO CHANGE WITHOUT NOTICE!

### Outputs

The "Key Out" and "Norm Out" outputs shall be 3-Pin XLR male jacks, balanced or unbalanced line-level.

Maximum output shall be 7.7 Vrms. Source impedance shall be 56  $\Omega$ . There shall be two independent 3.5 mm TRS headphone output jacks (left right). The headphone outputs shall allow the use of either mono or stereo headphones, 8-32  $\Omega$ . Maximum power shall be 63 mW at 8  $\Omega$ .

### Controls

The unit shall have two, independent rotary-type volume controls, controlling headphone volume. The "Microphone" switch shall be a 3-way toggle type, selecting left mic, right mic or both. The mute switch shall be a push button-type, muting left and right mics when depressed. The function switch shall be a 4-way push button-type, selecting OFF, NORM, RELAY or KEY modes.

### Controls

Feedthru jumpers used to select floor signal feedthru options shall be located on bottom of cabinet.